

MONZA CAP KIT

Kit Suitable for

- Triumph Twins 2001-2015 (T100, Thruxton, SE, Scrambler)
- Triumph Twins 2016-Present (Bobber, T100, T120, Street Cup, Street Twin etc)
- Harley Davidson 1983 and Up (Sportster, Dyna, etc)

NMX002

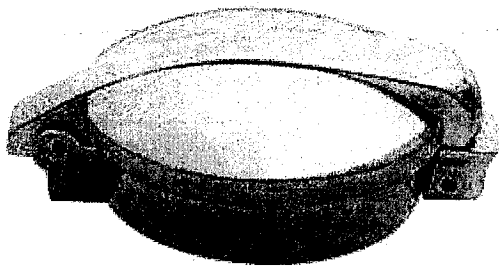

NMX003

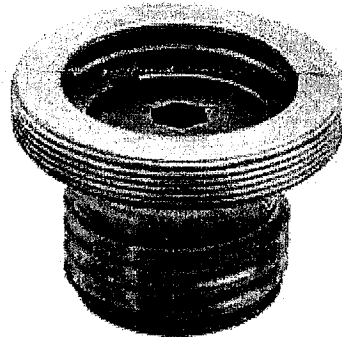

Before Assembly Please note the following points :

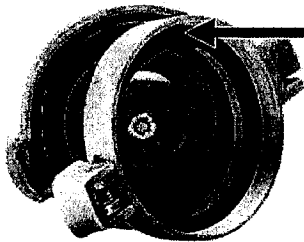

Top Cap assembly NMX002 comes bundled with this flat rubber gasket on the inside. When combined with the components in NMX003 this particular gasket is unnecessary and so can be removed from the kit.

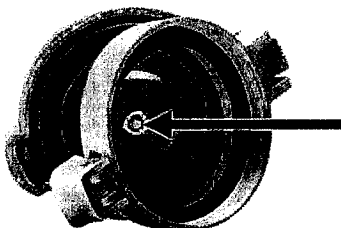

This lock nut holds the NMX002 top cap assembly together. Some adjustment of the nut is possible to alter the rate at which the cap springs open when in use. Check this nut is properly wound onto the bolt before proceeding further to ensure it doesn't fall off the thread into the tank.

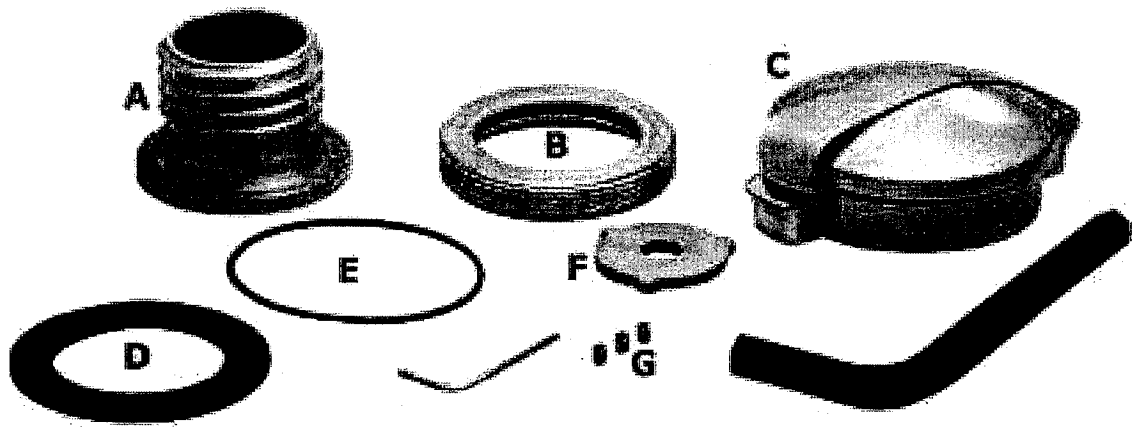

1. Place the large flat rubber gasket **D** under the adapter piece **A**. The thinner o-ring **E** goes between the ring adapter **B** and the Monza top cap **C**. Screw the assembly together.

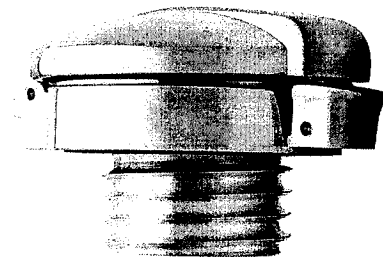
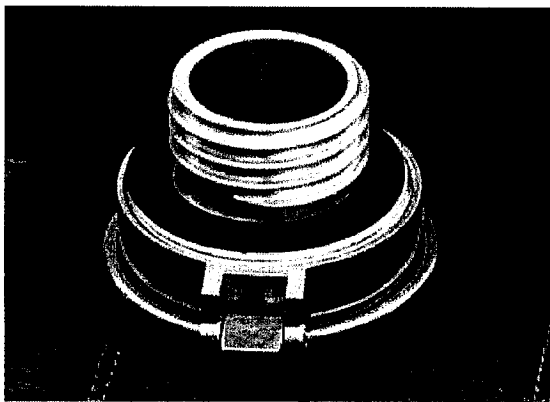

2. Present the complete assembly into the fuel tank, and screw it in without tightening; at this point the cap will almost certainly be at the wrong angle (you want the cap to be aligned with the bike, and open towards the front).
3. Unscrew the assembly about 90 degrees (1/4 of a turn), open the flip-top part of the cap and insert the special tool **F** in the base. Place the larger allen key supplied in the special tool.
4. Holding the allen key in one hand, use your other hand to rotate the cap assembly to the correct angle.
5. Then tighten the centre part of the cap with the allen key/special tool while holding the outer part of the assembly at the correct angle.
6. Tighten the 3 grub nut/set-screws (**G**) using the smaller allen key to secure the cap onto the tank, in alignment with the bike. Remove the special tool and retain for future use.

